

Gamesa G9X-2.0 MW

Technological Evolution



G97

G90

G87

G80

Gamesa



2.0 MW



Gamesa

G9X

P.4

Economic progress and sustainable development.

P.5

Innovative evolution.

P.6

Global capacity for production, installation and operation and maintenance.

P.8

Discovering the Gamesa G9X-2.0 MW:

Maximum productivity.
Advantages of the Gamesa G9X-2.0 MW platform.
Technical characteristics.



Economic progress & Sustainable development

These are the great challenges facing today's society. In the areas of energy management and power generation, Gamesa is tackling these challenges by developing technologies that foster energy sustainability in a clean, efficient and profitable manner.

By harnessing the best and most modern technologies in conjunction with its high industrial potential, Gamesa continues to improve the efficiency and capacity of its products and services by designing and manufacturing of ever more advanced wind turbines.

The drive behind our work to develop more efficient technologies, products and services is to ensure that Gamesa's range of products is the most comprehensive in terms of capabilities and the most competitive in the market. That in turn guarantees complete customer satisfaction.



G9X

Innovative Evolution

Technology is one of the fundamental focal points of Gamesa's activities, evidenced by the substantial research and development efforts employed by the company to continually improve to its Gamesa G8X-2.0 MW platform.

Wind turbine technology characterized by robustness, reliability and adaptability to all types of sites and wind conditions, from the toughest, most demanding locations to situations with medium to light winds. This is a technology that has been very well received for which a growing demand has been felt right from the beginning,

backed by a very high adaptation capacity proven by the 10,500 MW of power installed in 19 countries.

The company's significant experience base and its in-depth knowledge of market needs and demands have enabled it to develop technological improvements in this platform. The evolution and incorporation of substantial innovations in design, products and features have created and put the new Gamesa G9X-2.0 MW platform on the path to leadership in the multi-megawatt segment.

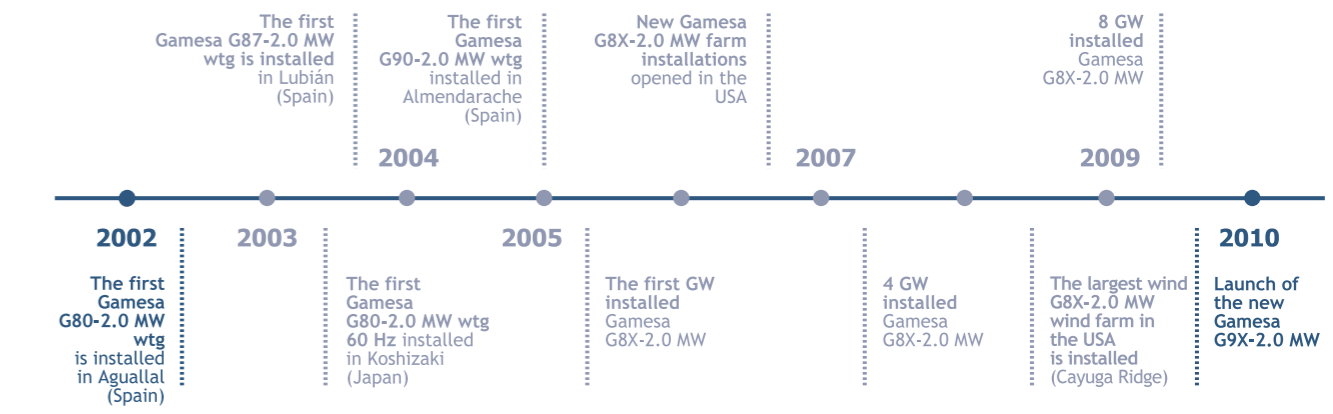



Gamesa specializes in sustainable energy technologies, primarily wind power. With more than 15 years experience, Gamesa is a world leader in the design, manufacture, installation and maintenance of wind turbines, with more than 21,500 MW installed in 29 countries on four continents.

Within this sector, Gamesa manages the entire process from design, manufacture and installation of wind turbines through and including their operation and maintenance.

Gamesa designs and manufactures its own blades and covers the entire process from molds, blade roots and spars to the external blade profile. Gamesa also works with external companies that manufacture other components that are particularly important in a wind turbine, such as the gear boxes, turbines and convertors, as well as the full assembly of the wind turbine.

Its industrial capacity allows Gamesa to fully control the production process of the various critical wind-turbine components from design through manufacture. In addition, Gamesa offers its customers the highest quality standards in short customer response times. With 31 production centers in Europe, the United States, China, India and Brazil, Gamesa has an annual production capacity of 4,400 MW and an international workforce of more than 7,800 employees.

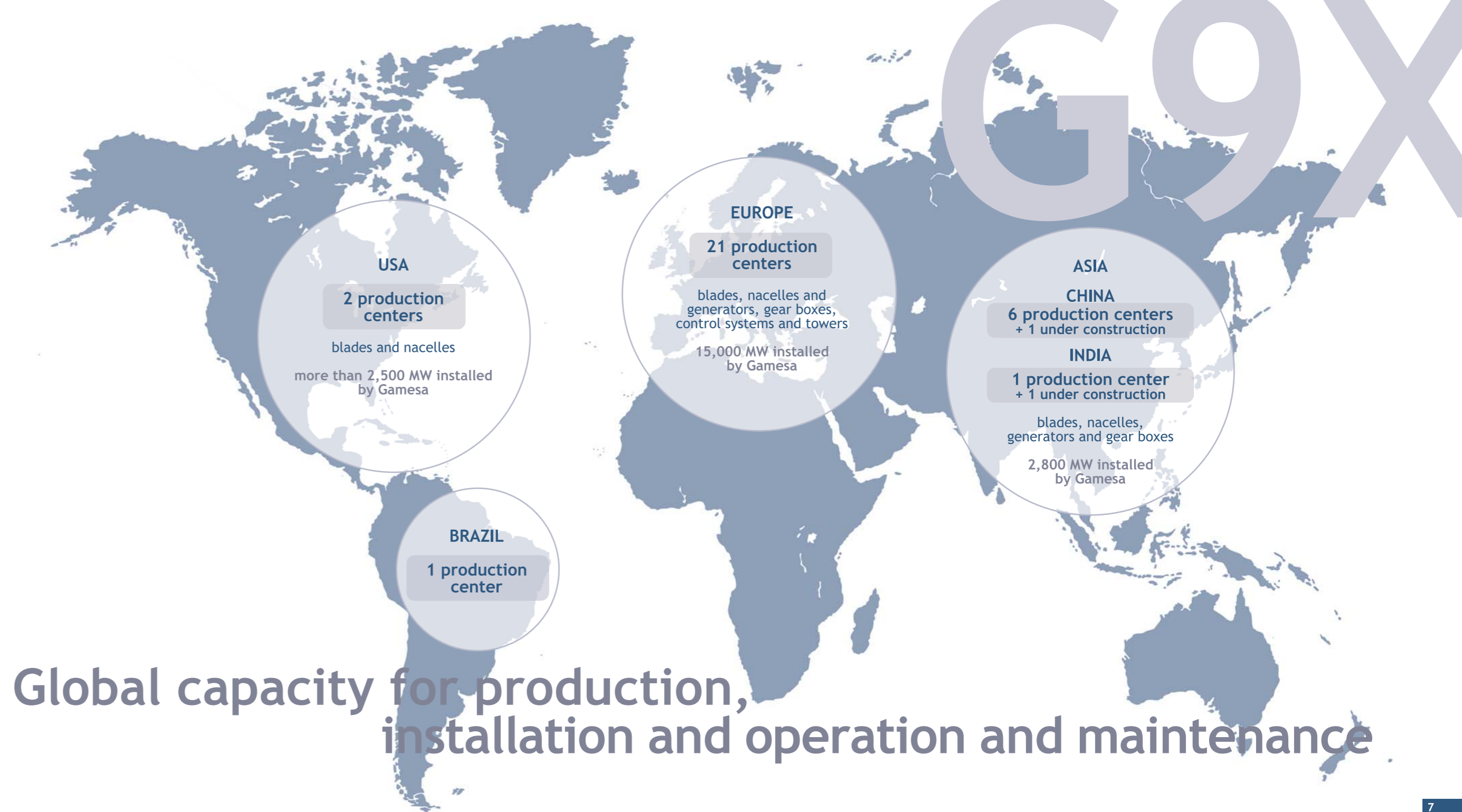

GO9X

Global capacity for production, installation and operation and maintenance

Versatility

Multi-megawatt wind turbines from the Gamesa G9X-2.0 MW platform improve competitive investment ratios per MW installed and Cost of Energy produced due to their versatile combination of a 2.0 MW unit power wind turbine and 4 different sized rotors: 80, 87, 90 and 97 m diameters, to achieve maximum output in all types of settings and wind conditions.

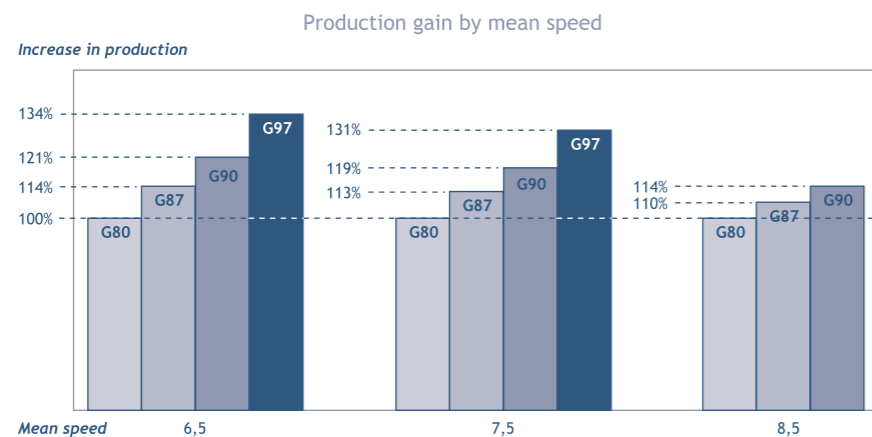
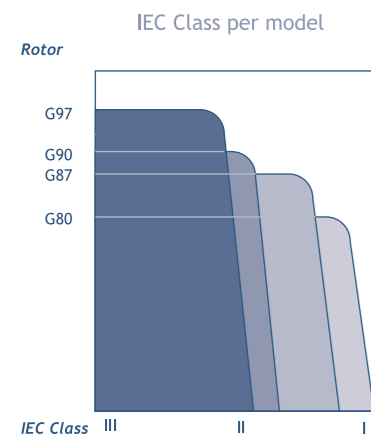

* NOTE: theoretical production calculated for k=2, density 1,225 kg/m3, with average speed at hub height

Platform Versatility:
site-specific offerings
optimizing energy
capture & maximizing
production

This is what Gamesa
G9X-2.0 MW wind
turbines can promise



The Gamesa G9X-2.0 MW bases its operational improvements from its speed control and variable pitch technology enhancements, and other hardware and software design upgrades to extract the maximum amount of energy from the wind and to do it as efficiently as possible.

- ☞ Composite materials reinforced with glass and carbon fiber for lighter blades without sacrificing rigidity and strength.
- ☞ The Gamesa WindNet® remote control system.
- ☞ Gamesa SMP predictive maintenance.
- ☞ Gamesa NRS® noise control.
- ☞ Solutions for optimum grid connection.

Model	IEC	Rated Power	Grid Code	Tower Heights	Env / Opt ⁽¹⁾	50 Hz	60 Hz
G80	IA	2,000 kW	✓	60, 67, 78, 100 ⁽²⁾ m	✓	✓	✓
G87	IA ⁽³⁾ /IIA	2,000 kW	✓	67, 78, 90, 100 m	✓	✓	✓
G90	IIA/IIIA	2,000 kW	✓	67 ⁽⁴⁾ , 78, 100 m	✓	✓	✓
G97	IIA/IIIA	2,000 kW	✓	78, 90, 120 ⁽⁵⁾ m	✓	✓	✓

(1) Different versions and optional kits are available to adapt machinery to high or low temperatures and saline or dusty environments.
 (2) 100 meter IEC IIA tower.
 (3) Will be certified as Class S, available with 78 and 90 m tower heights.
 (4) Availability depending on the site.
 (5) Under development.



Innovative Evolution
Gamesa G9X-2.0 MW

One step forward

Advantages of the new Gamesa G9X-2.0 MW platform

- ☞ Platform Versatility: site-specific offerings optimizing energy capture & maximizing production.
- ☞ New, latest generation 97-meter rotor for light and medium winds which, together with the 80-, 87- and 90-meter rotors makes this the most versatile platform on the market.
- ☞ Variable pitch and speed technology maximize energy production.
- ☞ State-of-the-art blade manufacturing technology. New optimized blade profiles guarantee maximum production and low noise.
- ☞ Technological solutions guarantee compliance with main international grid connection requirements.
- ☞ Gamesa active yaw system ensures optimum adaptation to complex terrain.
- ☞ Aerodynamic design and the Gamesa NRS[®] control system minimize noise emissions.
- ☞ Gamesa WindNet[®]: remote control and monitoring system with web access.
- ☞ Gamesa SMP: Own system for predictive maintenance.



Advantages of the new Gamesa G9X-2.0 MW platform

- Platform Versatility: site-specific offerings optimizing energy capture & maximizing production.
- New, latest generation 97-meter rotor for light and medium winds which, together with the 80-, 87- and 90-meter rotors makes this the most versatile platform on the market.
- Variable pitch and speed technology maximize energy production.
- State-of-the-art blade manufacturing technology. New optimized blade profiles guarantee maximum production and low noise.
- Technological solutions guarantee compliance with main international grid connection requirements.
- Gamesa active yaw system ensures optimum adaptation to complex terrain.
- Aerodynamic design and the Gamesa NRS[®] control system minimize noise emissions.
- Gamesa WindNet[®]: remote control and monitoring system with web access.
- Gamesa SMP: Own system for predictive maintenance.

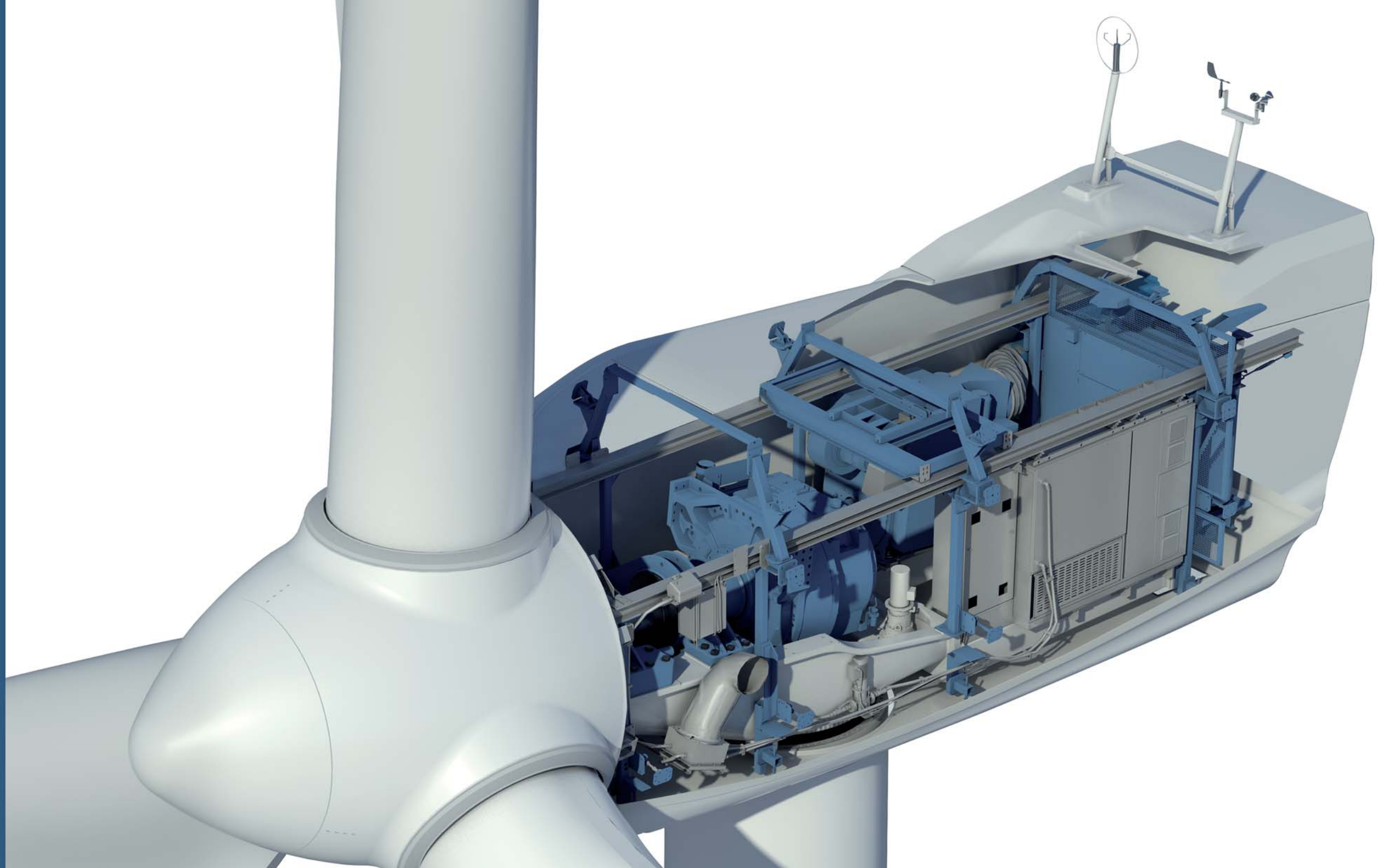

The reliability of the Gamesa G8X-2.0 MW, backed by broad experience and proven capacity to adapt,

10,500 MW installed

Operating in 19 countries

Established & vertically integrated manufacturing capabilities in the three main wind markets: Europe, China & the USA

are joined with the Gamesa G9X-2.0 MW technological advances providing notable improvements in performance, optimized models, a new tower portfolio and an upgraded image.

New features and improvements

- Maximum output under any wind condition.
- Enhanced power curves.

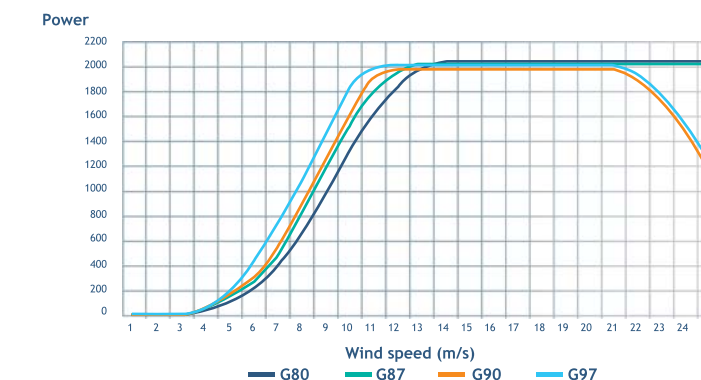

Optimized models

- New model Gamesa G97-2.0 MW / IIA-III.A.
- Optimized models: Gamesa G87-2.0 MW/IA, Gamesa G90-2.0 MW/IIA.

- Reduced noise levels: Aerodynamic design. Gamesa NRS[®] control system.

- New optimized blade profile for the new Gamesa G97-2.0 MW: Optimized blade root with high thickness blade profiles. Lighter blades through the use of fiber glass, carbon fiber and preimpregnation methods. Patent on blade root profile family.



Maximum energy production and reduced noise emissions

New tower portfolio

- Optimization of the 78-meter tower (from 4 to 3 sections).
- The new 90 meter tower.
- 120 m tower height under development.

Upgraded nacelle profile

- Newer, more attractive nacelle design.
- Improvements and capacity increases on key drive train components.
- Expanded space for nacelle maintenance tasks and operations.

G9X

Discovering Gamesa G9X-2.0 MW

Gamesa G9X-2.0 MW

Technical specifications and services

Mechanical design: Optimum reliability and performance

The Gamesa G9X-2.0 MW incorporates improved and increased mechanical capacity in key wind-turbine components such as the yaw system, the framework, main axis and blade bearings. These improvements guarantee maximum reliability of the equipment and allow larger rotors to be used to increase the power generated in medium and light winds.

Drive train

The main axis is supported on two spherical bearings that provide significant advantages since lateral loads are transmitted directly to the framework through a rack. This prevents the gear box from receiving additional, unwanted loads, thus reducing the possibilities of breakdown as well as providing a longer service life.

Controlled brake system

The joint action of the primary aerodynamic brakes and mechanical emergency brake (located at the output of the high-speed axis of the gear box) with a hydraulic control system, allows controlled braking that prevents damage due to excessive transmission load.

Total lightning protection

The Gamesa G9X-2.0 MW platform uses the "Total Lightning Protection" system, designed according to the IEC 62305 standard. This system conducts the lightning from both sides of the tip of the blade to the root, and from there, through the nacelle and the tower structure, to the foundation grounding system. This protects the blade and prevents the lightning from going through the blade bearings and main axis, protecting sensitive electrical and electronic elements from becoming damaged.



Gamesa WindNet®, Real-time Operation and Monitoring

New generation SCADA wind farm system, entirely developed by Gamesa, which allows remote operation and the monitoring of wind turbines in real time, meteorological mast and electrical substation.

An innovative, modular design based on TCP/IP architecture. Control features include active and reactive power, voltage and frequency regulation tools and environmental options to optimize production while complying with the current regulations.

Accessible anywhere through a Web browser, WindNet is simple to use and intuitive. It features the Report Generator and Information Manager decision-taking analytical tools as well as TrendViewer, an advanced tool to visualize trends.

Designed for simple maintenance

Gamesa's global response also offers a wide range of operational and maintenance options. Equipment supplied by the company comes with a two-year warranty on components, availability and power curves as well as a maintenance service, all standard.

But Gamesa's commitment to its customers does not end there. The company developed an Integral Management Service comprising of a long-term operation and maintenance contract (up to 15 years), providing wider coverage to guaranteeing maximum availability, ensuring long-term costs to operate the wind farm are known and assisting in smoothing out the road to funding.

Through detailed analysis of its extensive operational experience, Gamesa also continuously adapts its equipment to the most demanding connection grids and environmental surroundings.



Control system: Maximum output under Any wind condition

Dual powered generator, speed and power controlled by IGBT converters and electronic PWM control (Pulse Width Modulation).

Advantages:

- ☞ Active and reactive power control.
- ☞ Low harmonic content and minimum losses.
- ☞ Increased efficiency and production.
- ☞ Improved useful life of the machine.

On-Line Condition Monitoring System for Predictive Maintenance (SMP)

Predictive maintenance system for premature detection of potential deterioration or faults in the main wind-turbine components.

Advantages:

- ☞ Fewer large corrections.
- ☞ Improved reliability, availability and useful life of the machine.
- ☞ Integration with the control system.
- ☞ Risk mitigation provides preferential conditions in negotiations with insurance providers.

Minimum Noise Emission Maximum Production

New aerodynamic design of the blade tip and mechanical components designs that minimize noise emissions.

In addition, Gamesa has developed the Gamesa NRS® noise control system, which makes it possible to program noise emissions according to such criteria as the date, time or wind direction.

This achieves compliance with local regulations and enables maximum production.



Optimum electrical grid connection and stable production

Gamesa's dual power wind turbines and Active Crowbar technologies and oversized converters guarantee compliance with the most demanding requirements for connection to current grids and future electric grid and wind farm configurations. Support for voltage-drop and dynamic active and reactive power regulation.

	Gamesa 80 MW	Gamesa 87 MW	Gamesa 90 MW	Gamesa 97 MW
ROTOR				
Diameter	80 m	87 m	90 m	97 m
Swept area	5,027 m ²	5,945 m ²	6,362 m ²	7,390 m ²
Rotational speed	9.0 - 19.0 rpm	9.0 - 19.0 rpm	9.0 - 19.0 rpm	9.6 - 17.8 rpm
BLADES				
Number of blades	3	3	3	3
Length	39 m	42.5 m	44 m	47.5 m
Airfoils	NACA 63.XXX + FFA-W3	DU + FFA-W3	DU + FFA-W3	Gamesa
Material	Pre-impregnated epoxy glass fiber	Pre-impregnated epoxy glass fiber	Pre-impregnated epoxy glass fiber + carbon fiber	Pre-impregnated epoxy glass fiber + carbon fiber
TOWER				
Type	Modular	Modular	Modular	Modular
Height	60, 67, 78 and 100 m	67, 78, 90 and 100 m	67, 78 and 100 m	78, 90 m (120 m tower height under development)
GEAR BOX				
Type	1 planetary stage 2 parallel stages	1 planetary stage 2 parallel stages	1 planetary stage 2 parallel stages	1 planetary stage 2 parallel stages
Ratio	1:100.5 (50 Hz) 1:120.5 (60 Hz)	1:100.5 (50 Hz) 1:120.5 (60 Hz)	1:100.5 (50 Hz) 1:120.5 (60 Hz)	1:106.8 (50 Hz) 1:127.1 (60 Hz)
GENERATOR 2.0 MW				
Type	Doubly-fed machine	Doubly-fed machine	Doubly-fed machine	Doubly-fed machine
Rated power	2.0 MW	2.0 MW	2.0 MW	2.0 MW
Voltage	690 V AC	690 V AC	690 V AC	690 V AC
Frequency	50 Hz / 60 Hz	50 Hz / 60 Hz	50 Hz / 60 Hz	50 Hz / 60 Hz
Protection class	IP 54	IP 54	IP 54	IP 54
Power factor	0.95 CAP - 0.95 IND throughout the power range*	0.95 CAP - 0.95 IND throughout the power range*	0.95 CAP - 0.95 IND throughout the power range*	0.95 CAP - 0.95 IND throughout the power range*

* Power factor at generator output terminals, on low voltage side before transformer input terminals





C/ Ciudad de la Innovación, 9-11
31621 Sarriguren (Espanha)
Tel: +34 948 771 000
Fax: +34 948 165 039
info@gamesacorp.com
www.gamesacorp.com

BRAZIL

Av Brigadeiro Faria Lima, 3729, Sala 429,
Pinheiros, CEP 404538-133
São Paulo (SP)
Tel: +5511 3443 7252

CHINA

Room 605,
CBD International Building
N.o 16, Yong An Dong Li,
Chaoyang District
Beijing 100022
Tel.: +86 10 6566 9388
Fax: +86 10 8521 9760

EGYPT

12 Dar el Shefa Street 3th. Floor,
Garden City- Cairo
Tel: +20 166642424
Fax: +20 227951866

FRANCE

Parc Mail, Bâtiment G
6 Allée Irène Joliot-Curie
69791 Saint Priest Cedex
Tel: +33 (0) 4 72 79 49 39

GERMANY

Wailandtstrasse 7
63741 Aschaffenburg
Tel: +49 (0) 6021 15 09 0
Fax: +49 (0) 6021 15 09 199
germany.wind@gamesacorp.com

INDIA

The Futura IT Park, B-Block, 8th Floor
334, Rajiv Gandhi Salai
Sholinganallur, Chennai - 600 119
Tel: +91 44 3924 2424
sales.india@gamesacorp.com

ITALY

Via Mentore Maggini 48/50
00143 Rome
Tel: +39 0645543650
Fax: +39 0645553974

JAPAN

Daiwa Jisho Building 4F – 411
74-1 Naka-ku,
Yamashita-cho
Yokohama-city 231-0023
Kanagawa
Tel: +81 45 680 50 80
Fax: +81 45 680 50 81

MEXICO

Torre Diana, Piso 14
Av. Pº de la Reforma 389
Colonia Cuahtemoc
06500 Mexico DF
Tel: +52 55 5093637

MOROCCO

345, Lot Gzennaya A B.P 397
Tangier (Boukhalef)
Tel: +212 539 393308/09
Fax: +212 539 393312

POLAND

Ul. Galaktyczna 30A
80-299 Gdansk
Tel: +48 58 766 62 62
Fax: +48 58 766 62 99
poland.wind@gamesacorp.com

UNITED KINGDOM

25 Napier Place
Wardpark North
Cumbernauld G68 0LL
Tel: +44 1236724890

UNITED STATES

2050 Cabot Boulevard West
Langhorne, PA 19047
Tel: +1 215 710 3100
Fax: +1 215 741 4048

SINGAPORE

3 Temasek Avenue
Centennial Tower - Level 34
Singapore 039190
Tel: +65 6549 7763
Fax: +65 6549 7011

TURKEY

Astoria
Buyukdere Cad. No. 127 Kule A, Kat 10
Esentepe
Istanbul 34394
Tel: +90 212 340 76 00